

6. 前后悬架/Suspension

序号/ No.	名 称 / Designation		页 码 /Page No.
6.01	70矿用自卸前悬架/Front Suspension	-----	1
6.02	70矿用自卸前稳定杆/Front Stabilizer bar	-----	3
6.03	70矿用自卸前减震器/Shock Absorber	-----	4
6.04	70矿用自卸后悬架/Rear Suspension	-----	6
6.05	70矿用自卸后稳定杆/Rear Stabilizer bar	-----	10

6.01 70矿用自卸前悬架/ Front Suspension

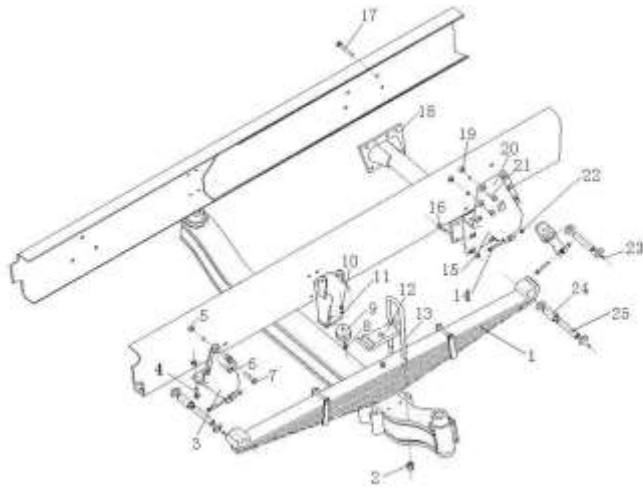

6.01 70矿用自卸前悬架/ Front Suspension

序号 No.	零部件图号 Part No.	名称	Part Name	数量 Qty	备注 Remark
1	WG9770520073	前钢板弹簧总成 (片厚14)	Front leaf spring assembly	2	
2	ZQ327B22T13F3	凸缘螺母M22*1.5	Nut	6	
3	WG9770524320	前簧前支架	Bracket	2	
4	ZQ151B1855TF6	六角头螺栓M18*1.5	Hexagon head bolts	4	
5	ZQ361B18T13F6	2型六角螺母M18*1.5	Hexagon nuts ,style 2	12	
6	ZQ151B1860TF6	六角头螺栓M18*1.5	Hexagon head bolts	12	
7	ZQ361B18T13F6	2型六角螺母M18*1.5	Hexagon nuts ,style 2	12	
8	WG80520019	紧固件	Fastener	2	
9	WG9750520017	前簧限位块	Front spring stop block	2	
10	ZQ340B10	1型六角螺母M10*1.5	Hexagon nuts ,style 1	2	
11	Q40310	弹簧垫圈	Springwasher	2	
12	WG9770520293	前弹簧压板	Front spring clamp	2	
13	AZ9770520270	前簧骑马螺栓	U-Bolt	4	
14	ZQ151B1650TF6	六角头螺栓M16*1.5	Bolt	16	
15	ZQ361B16T13F6	2型六角螺母M16*1.5	Hexagon nuts ,style 2	16	
16	ZQ151B1650TF6	六角头螺栓M16*1.5	Bolt	4	
17	ZQ151B1660TF6	六角头螺栓M16*1.5	Bolt	1	
18	WG9770510100	横梁总成	Cross member assembly	1	
19	ZQ361B16T13F6	2型六角螺母M16*1.5	Hexagon nuts ,style 2	5	
20	WG9770520456	前簧后支架	Rear bracket	2	

6.01 70矿用自卸前悬架/ Front Suspension



6.02 70矿用自卸前稳定杆/ Front Stabilizer bar

序号 No.	零部件图号 Part No.	名称	Part Name	数量 Qty	备注 Remark
1	WG9770681048	前稳定杆总成	Stabilizer bar assembly	1	
2	WG9770680050	销	Pin	2	
3	ZQ151B14110TF	六角头螺栓M14*1.5	Hexagon head bolts	4	
4	WG80 680029	螺栓	Bolt	2	
5	1780 680030	垫圈	Washer	2	
6	ZQ361B16	2型六角螺母M16*1.5	Hexagon nuts ,style 2	2	
7	WG9770680055	前平衡夹总成		2	
8	WG9770680053	支架	Bracket	2	
9	ZQ151B1645	六角头螺栓M16*1.5	Hexagon head bolts	4	
10	ZQ361B16	2型六角螺母M16*1.5	Hexagon nuts ,style 2	4	
11	WG9100680071	垫圈	Washer	2	
12	199100680037	套筒	Sleeve	2	
13	199100680066	轴承	Bearing	4	
14	WG80 680029	螺栓	Bolt	2	
15	1780 680030	垫圈	Washer	2	
16	190003930010	垫圈	Washer	2	
17	ZQ361B16	2型六角螺母M16*1.5	Hexagon nuts ,style 2	2	
18	WG9100680067	橡胶轴承	Rubber bearing	2	
19	WG9770680024	固定夹块	Block	2	
20	WG9770680027	垫板	Plate	2	

6.03 70矿用自卸前减震器/ Shock Absorber

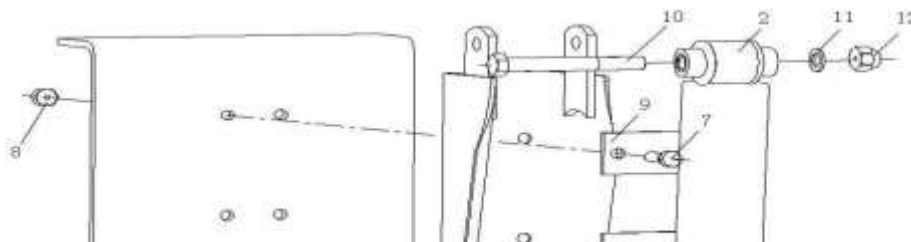

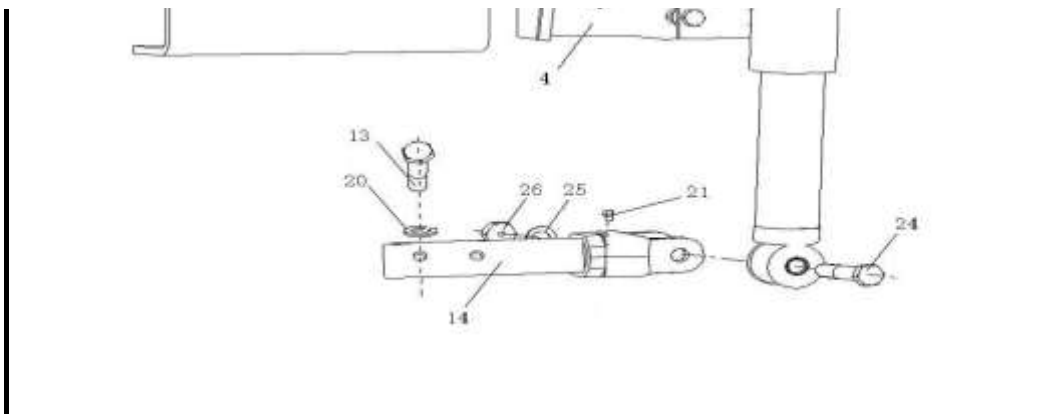

6.03 70矿用自卸前减震器/Shock Absorber

序号 No.	零部件图号 Part No.	名称	Part Name	数量 Qty	备注 Remark
1	199114520100	前悬架	Front suspension	1	
2	WG9725680014	减振器	Shock absorber	2	
4	WG9770680020	减振器支架总成	Shock absorber support ass	2	
6	Q151C1240	六角头螺栓	Bolt	1	
7	Q151C1235	六角头螺栓(细牙)	Bolt	7	
8	190003888457	自锁螺母	Nut	8	
9	199100680021	垫板	Plate	4	
10	Q151B16120	六角头螺栓	Bolt	2	
11	Q40016	小垫圈	Washer	2	
12	190003888459	自锁螺母	Nut	2	
13	Q151B1670	六角头螺栓	Bolt	4	
14	AZ9100680065	减震器下支架分装总成	Shock absorber bracekt ass	2	
15	WG9100680065	支架	Bracket	1	
17	WG9012680025	下支架连接叉	Bracket attachment fork	1	
19	190003933242	轴用弹性挡圈	Circlip	1	
20	Q40316	弹簧垫圈	Spring washer	4	
21	AZ9003963030	滑脂嘴总成	Grease nipple	2	
22	190003963112	米制锥螺纹滑脂嘴	Grease nipple	1	
23	AZ9003963010	滑脂嘴帽	Cap	1	
24	199012680009	螺栓	Bolt	2	

6.04 70矿用自卸后悬架/Rear Suspension

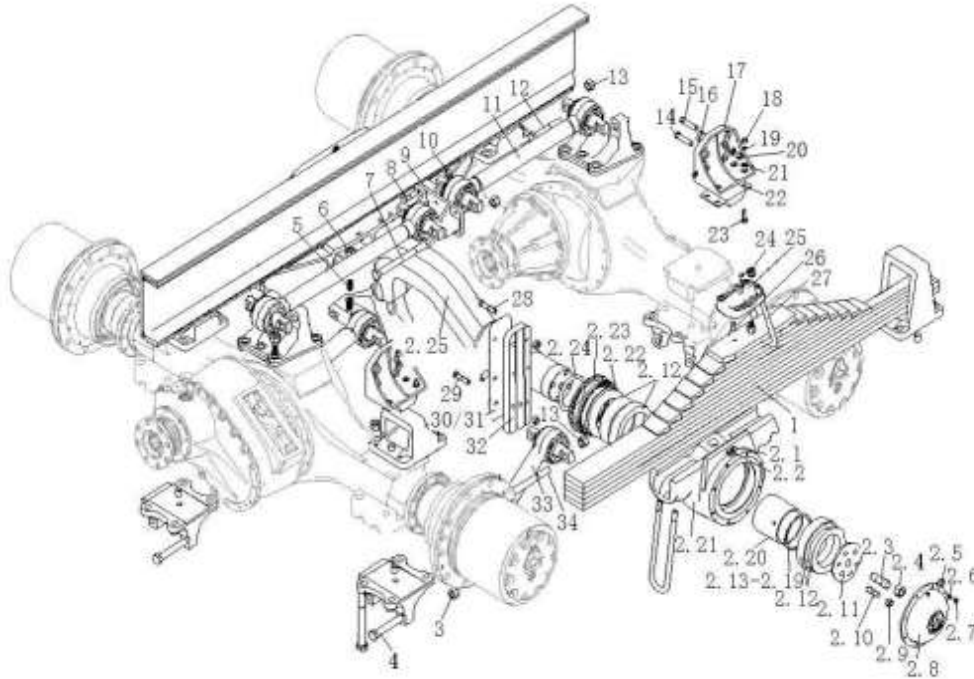

6.04 70矿用自卸后悬架/Rear Suspension

序号 No.	零部件图号 Part No.	名称	Part Name	数量 Qty	备注 Remark
1	WG9770520015	后钢板弹簧总成	Rear leaf spring	2	
1,1	WG9770520015+	后钢板弹簧总成第一片	1st piece of rear spring	1	
1,10	WG9770520015+	后钢板弹簧总成第十片	10th piece of rear spring	1	
1,11	WG9770520015+	后钢板弹簧总成第11片	11th piece of rear spring	1	
1,12	WG9770520015+	后钢板弹簧总成第12片	12th piece of rear spring	1	
1,13	WG9770520015+	后钢板弹簧总成第13片	13th piece of rear spring	1	
1,14	WG9770520015+	后钢板弹簧总成第14片	14th piece of rear spring	1	
1,15	WG9770520015+	后钢板弹簧总成第15片	15th piece of rear spring	1	
1,16	WG9770520015+	中心螺栓	Center bolt	1	
1,17	WG9770520015+	中心螺母	Center nut	1	
1,2	WG9770520015+	后钢板弹簧总成第二片	2nd piece of rear spring	1	
1,3	WG9770520015+	后钢板弹簧总成第三片	3rd piece of rear spring	1	
1,4	WG9770520015+	后钢板弹簧总成第四片	4th piece of rear spring	1	
1,5	WG9770520015+	后钢板弹簧总成第五片	5th piece of rear spring	1	
1,6	WG9770520015+	后钢板弹簧总成第六片	6th piece of rear spring	1	
1,7	WG9770520015+	后钢板弹簧总成第七片	7th piece of rear spring	1	
1,8	WG9770520015+	后钢板弹簧总成第八片	8th piece of rear spring	1	
1,9	WG9770520015+	后钢板弹簧总成第九片	9th piece of rear spring	1	
2	AZ9770520610	平衡轴带轴壳总成	Balance shaft assembly	1	
2,1	ZQ150B0810	六角头螺栓M8	Hexagon head bolts	2	

6.04 70矿用自卸后悬架/Rear Suspension



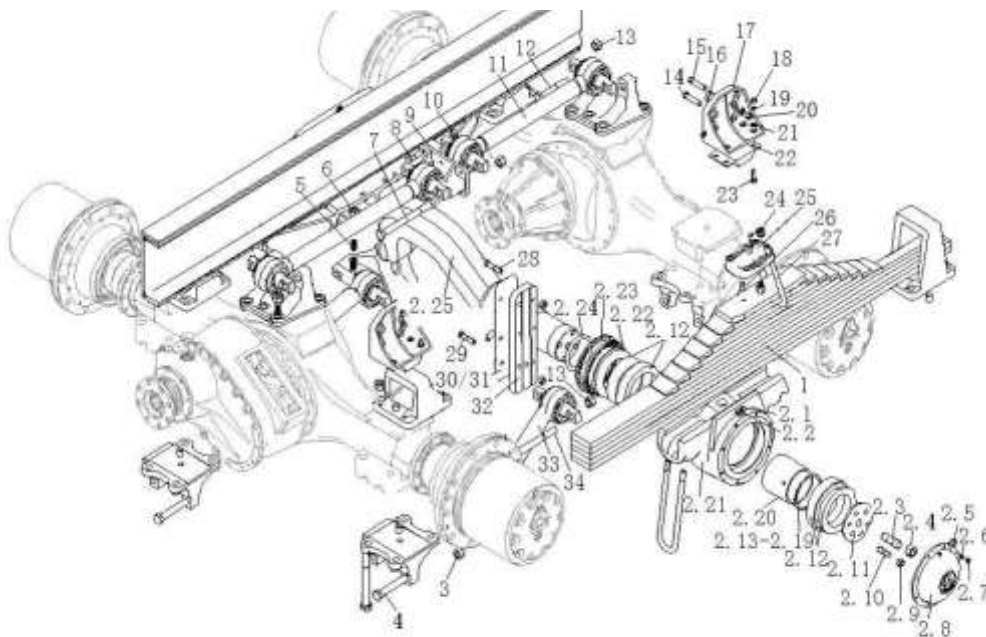

6.04 70矿用自卸后悬架/Rear Suspension

序号 No.	零部件图号 Part No.	名称	Part Name	数量 Qty	备注 Remark
2,10	WG9770520227	双头螺柱	Stud	12	
2,11	WG9770520188	轴承压块	Block	2	
2,12	WG9770520142	球面轴承	Bearing	4	
2,13	WG9770520192	定位垫圈	Washer	2	
2,14	WG9770520193	定位垫圈	Washer	2	
2,15	WG9770520194	定位垫圈	Washer	2	
2,16	WG9770520195	定位垫圈	Washer	2	
2,17	WG9770520196	定位垫圈	Washer	2	
2,18	WG9770520197	定位垫圈	Washer	2	
2,19	WG9770520198	定位垫圈	Washer	2	
2,2	WG9770520238	间隔衬套	Bushing	2	
2,20	Q72308T5F	密封垫圈	Gasket	2	
2,21	WG9770520235	平衡轴壳	Housing	2	
2,22	WG9770520136	轴承油封盖	Cover	2	
2,23	WG9770520223	轴密封圈	Gasket	2	
2,24	WG9770520262	密封圈	Gasket	2	
2,25	AZ9770520600	平衡轴总成	Balance shaft assembly	1	
2.25.1	AZ9770520185	平衡轴	Balance shaft	1	
2.25.2	AZ9770520329	支架	Bracket	2	
2.25.3	Q5211675	圆柱销	Pin	4	

6.04 70矿用自卸后悬架/Rear Suspension

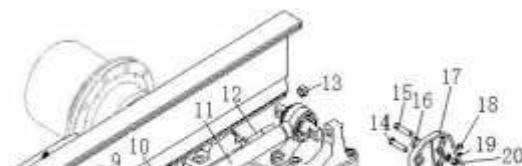

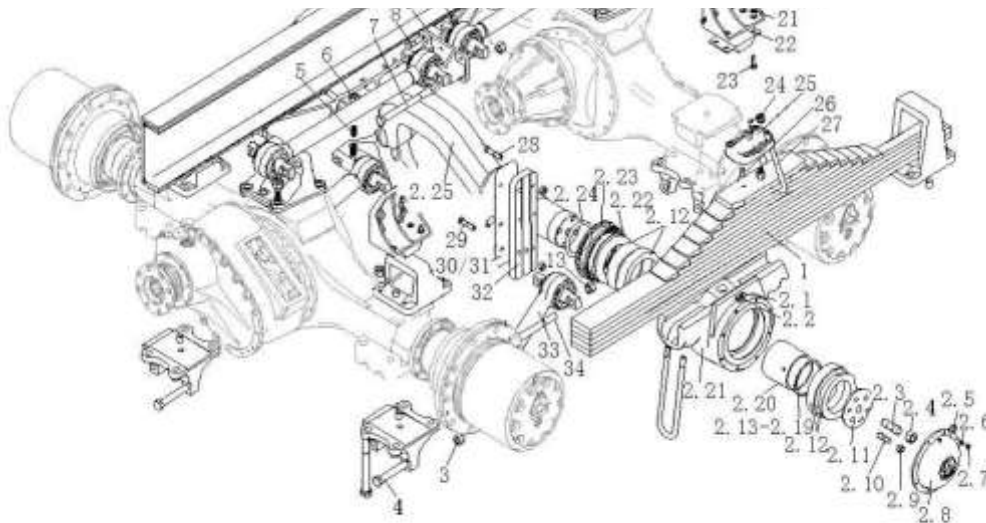

6.04 70矿用自卸后悬架/Rear Suspension

序号 No.	零部件图号 Part No.	名称	Part Name	数量 Qty	备注 Remark
2,3	WG9770520228	双头螺柱	Stud	2	
2,4	ZQ32727T13F3	凸缘螺母M27*3	Nut	2	
2,5	190003962021	锥螺纹内六角螺塞	Plug	2	
2,6	Q40308	弹簧垫圈	Spring washer	20	
2,7	ZQ150B0820	六角头螺栓M8	Hexagon head bolts	20	
2,8	WG9770520311	壳盖	Cover	2	
2,9	ZQ32722T13F3	凸缘螺母M22	Nut	12	
3	ZQ32727T13F3	凸缘螺母M27*3	Nut	12	
4	WG9770520135	六角头螺栓 (M27X3, 12.9)	Bolt	8	
5	ZQ151B1690TF6	六角头螺栓M16*1.5	Hexagon head bolts	12	
6	ZQ361B16T13F6	2型六角螺母M16*1.5	Hexagon nuts ,style 2	36	
7	WG9770520340	六角头螺栓 (M27X3, 12.9)	bolt	2	
8	ZQ151B18110TF	六角头螺栓M18*1.5	Hexagon head bolts	6	
9	WG9770520027	托架	Bracket	2	
10	ZQ361B18T13F6	2型六角螺母M18*1.5	Hexagon nuts ,style 2	6	
11	AZ9770523275	上推力杆总成	longitudinal rod assembly,	2	
12	WG9770520135	六角头螺栓 (M27X3, 12.9)	Bolt	4	
13	ZQ32727T13F3	凸缘螺母M27*3	Nut	6	
14	ZQ151B1475	六角头螺栓M14*1.5	Hexagon head bolts	8	
15	ZQ151B1465	六角头螺栓M14*1.5	Hexagon head bolts	8	

6.04 70矿用自卸后悬架/Rear Suspension

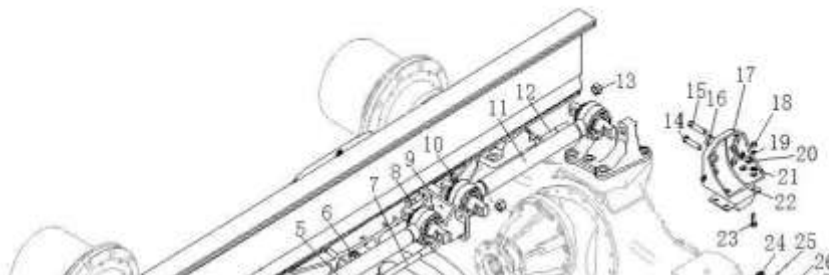

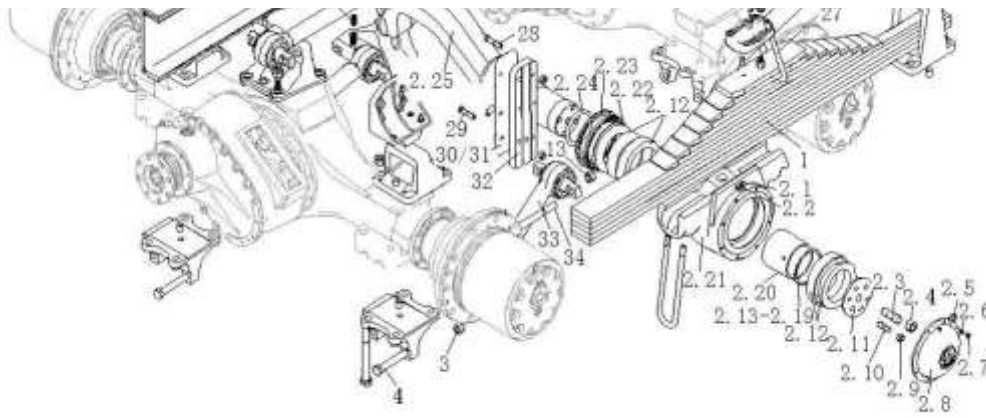

6.04 70矿用自卸后悬架/Rear Suspension

序号 No.	零部件图号 Part No.	名称	Part Name	数量 Qty	备注 Remark
16	WG9100520112	垫块	Block	4	
17	WG9114520098	限位块支架	Bracket	4	
18	Q340B10	六角螺母	Nut	16	
19	Q40310	弹簧垫圈	Spring washer	16	
20	ZQ361B14	2型六角螺母M14*1.5	Hexagon nuts ,style 2	16	
21	Q40110	平垫圈	Washer	16	
22	WG9770521091	限位块总成	Block assembly	4	
23	ZQ150B1035	六角头螺栓M10	Hexagon head bolts	16	
24	ZQ32730T13F3	凸缘螺母M30*3	Nut	16	
25	WG9770520266	板簧压块	Block	2	
26	WG9750520006	导向销	Pin	4	
27	AZ9770520361	后簧骑马螺栓	U-bolt	8	
28	ZQ151B1470	六角头螺栓M14*1.5	Hexagon head bolts	16	
29	ZQ151B1660	六角头螺栓M16*1.5	Hexagon head bolts	12	
30	AZ9770520224	平衡板	Plate	4	
31	AZ9770520225	平衡板	Plate	4	
32	WG9770521258	导向板	Guide plate	4	
33	AZ9770523274	下推力杆总成	longitudinal rod assembly,	4	
34	WG9770520325	六角头螺栓 (M27X3, 12.9)	bolt	4	
35	ZQ151B1650TF6	六角头螺栓M16*1.5	Hexagon head bolts	24	

6.05 70矿用自卸后稳定杆/Rear Stabilizer bar





6.05 70矿用自卸后稳定杆/Rear Stabilizer bar

序号 No.	零部件图号 Part No.	名称	Part Name	数量 Qty	备注 Remark
1	199100520052	后悬架	Rear suspension	1	
2	WG9770680064	后稳定杆总成	Stabilizer bar assembly	1	
4	WG9770680075	平衡夹总成	Circlip assembly	2	
6	WG9100680071	垫圈	Washer	2	
8	199100680037	套筒	Sleeve	2	
9	199100680066	轴承	Bearing	4	
10	WG80 680029	螺栓	Bolt	2	
11	1780 680029	螺栓	Bolt	1	
14	1780 680030	垫圈	Washer	2	
15	190003930010	垫圈	Washer	2	
16	190003888459	自锁螺母	Nut	2	
17	WG9100680067	橡胶轴承	Rubber bearing	2	
18	WG780680032	轴承夹	Bearing clip	2	
20	Q151C12100	六角头螺栓	Bolt	4	
21	190003888457	自锁螺母	Nut	4	
22	WG80 680029	螺栓	Bolt	2	
23	1780 680029	螺栓	Bolt	1	
26	1780 680030	垫圈	Washer	2	
27	190003888459	自锁螺母	Nut	2	